

ReeFlex 150 Basic

Fully Automatic Tray Sealer Machine



Dati Tecnici	Technical Data	Technische Daten	Datos técnicos	ReeFlex 150 Basic
Altezza macchina	Machine height	Maschinenhoehe	Altura máquina	1795 mm
Larghezza macchina	Machine width	Maschinenbreite	Ancho máquina	916 mm
Lunghezza macchina	Machine length	Maschinenlaenge	Largo máquina	2770 mm - 3182 mm
Peso totale	Weight	Gesamtgewicht	Peso total	ca. 700 Kg
Max larghezza film sigillatura	Max width of top web	Max. Breite der Siegelfolie	Máx ancho film de sellado	420 mm
Max diametro bobina film	Max diameter of web roll	Max. Durchmesser der Siegelfolie	Máx diámetro bobina película	300 mm
Diametro albero supporto bobina	Diameter of film support shaft	Durchmesser der Folienaufnehmerolle	Diámetro mandril bobina	70 - 76 mm
Pompa vuoto	Vacuum Pump	Vakuumpumpe	Bomba de vacío	60 m ³ / h
Alimentazione elettrica	Electrical supply	Elektrischer Anschluss	Alimentación eléctrica	3/N/PE AC 400V 50 Hz
Potenza elettrica	Power consumption	Leistung	Potencia eléctrica	3 - 5 Kw
Aria compressa	Compressed air	Druckluft	Aire comprimido	6 bar - 30 NI/c
N.cicli macchina	Machine capacity	Leistung der Maschine	Num.ciclos máquina	3 - 7 cycles/min*

*I cicli macchina sono in funzione e dipendono dalla configurazione della macchina, dalla qualità dei materiali utilizzati e dal prodotto da confezionare. / Cycle speed depending on: material quality of tray and film web, tray size, product to pack and general machine configuration. / Die Leistung der Maschine ist abhängig, von der Qualität der Schale und Folie, der Schalenabmessungen, der Eigenschaft des zu verpackenden Produktes und der Konfiguration der Maschine. / Los ciclos de la máquina están en función de la configuración de la misma máquina y dependen de la calidad de los materiales utilizado a envasar y del producto a empaquetar.

Optional macchina	Optional Machine	Maschinen Optionen	Extras Máquina	ReeFlex 150 Basic
Fotocellula per film stampato	Photocell for printed film	Fotozelle fuer Bedruckte Folie	Fotocélula para film impreso	√
Filtro per liquidi e polveri	Liquid and powder filter	Staub - und Flüssigkeitsfilter	Filtro líquidos y polvos	√

Lay-out ReeFlex 150 Basic

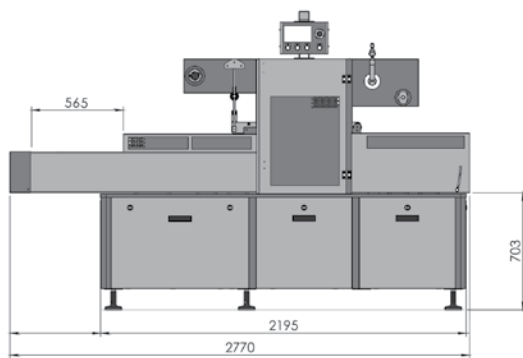

1 posizione vaschetta
1 tray position
1 Schalen Position

Optional:

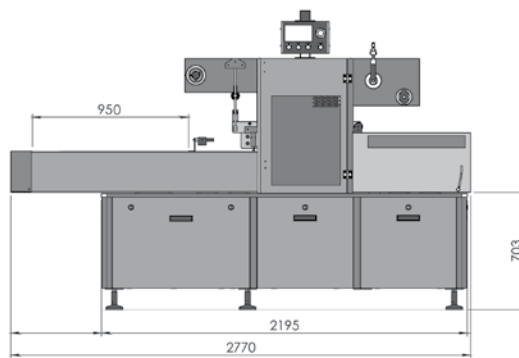

2 posizioni vaschetta
2 tray positions
2 Schalen Positionen

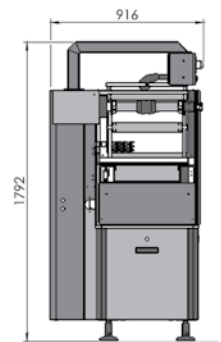

Numero e massime misure vaschette per ciclo. / Number and max. tray dimensions processed per cycle.
Anzahl und max. Schalenabmessungen/Zyklus. / Número y dimensiones máximas de bandejas que se pueden sellar por ciclo.



Direzione film e vaschette / Tray and film direction
Folienaufrichtung / Sentido de film y envases.

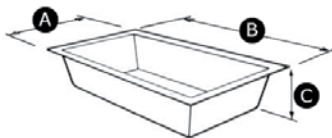

N. 1

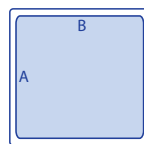

A= 365 mm
B= 350 mm
C= 130 mm

N. 2

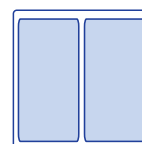

A= 180 mm
B= 350 mm
C= 130 mm

N. 3

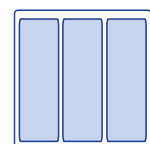

A= 116 mm
B= 350 mm
C= 130 mm

Si riserva la facoltà di apportare modifiche ai dati esposti senza alcun preavviso. / In keeping with improvements, designs and specification subject to change without notice. / Die genannten technischen Angaben, sowie die Abbildungen in diesem Prospekt unterliegen laufender Verbesserungen. Daher sind diese unverbindlich und können ohne vorherige Ankündigung jederzeit geändert werden. / Se reserva la facultad de aportar modificaciones a los datos expuestos sin ningún aviso previo.

Reepack s.r.l.
Via dell'Artigianato,19
24068 Seriate (BG) Italy
Tel.: +39 035 2924911
Fax: +39 035 2922891
reepack-it@reepack.com

Reepack Verpackungsmaschinen GmbH
An der Tumppe 5
58791 Werdohl-Dresel - Germany
Tel.: +49 (0)2392 8079480
Fax: +49 (0)2392 80794899
reepack-de@reepack.com

Reepack Packaging Machinery S.L.
Pasaje Salvador Riera, 13 local
08027 Barcelona - Spain
Tel.: +34 90 210 38 26
Fax: +34 93 787 51 18
reepack-es@reepack.com