

# ReeForm

Thermoforming Machine

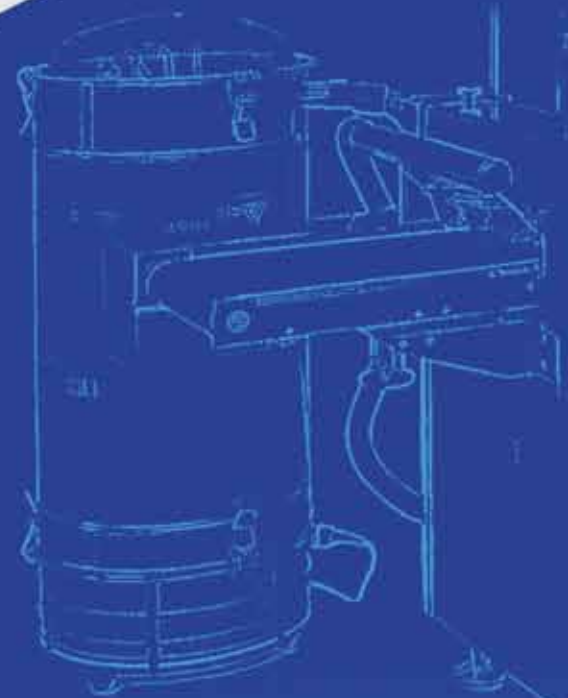

Dati Tecnici	Technical Data	Technische Daten	ReeForm 350	ReeForm 420
Dimensioni totali	Overall dimensions	Allgemeine Abmessungen	3450 x 975 x 1570	4900 x 1050 x 1780
Lungh. piano carico	Length of loading	Länge der freien Einlegestrecke	1000 mm	1000 / 1500 mm - modular
Altezza piano di carico	Height of loading area	Arbeitshöhe	900 ± 15 mm	900 ± 15 mm
Peso totale	Weight	Gesamtgewicht	ca. 950 kg	ca. 1200 kg
Max dimensione cavità	Max cavity dimensions	Größte Packungsabmessung	297 x 239 mm	379 x 239 mm
Max profondità cavità	Max cavity depth	Max. Ziehtiefe	100 mm/ opt. 130 mm	100 mm/ opt. 130 mm
Passo macchina	Machine stroke	Vorzug	max 300 mm (with pre-heating max 150)	max 400 mm
Max larghezza film termoformatura	Max width bottom film roll	Max. Breite untere Folienrolle	350 mm	min 320 - max 420 mm
Max larghezza film di sigillatura	Max width top film	Max. Breite obere Folienrolle	320 mm	min 300 - max 400 mm
Max diametro esterno bobina inf.	Max diameter bottom film roll	Max. Durchmesser unteren Filmrolle	350 mm	400 mm
Max diametro esterno bobina sup.	Max diameter top film roll	Max. Durchmesser obere Folienrolle	300 mm	300 mm
Diametro mandrino bobina	Diameter of web roll mandrel	Hülsendurchmesser beider Folien	76 mm	76 mm
Alimentazione elettrica	Electrical supply	Elektrischer Anschluss	3/N/PE AC 400V 50 Hz	3/N/PE AC 400V 50 Hz
Assorbimento	Power consumption	Stromaufnahme	min.4 Kw - max. 9,5 Kw	min. 9,2 Kw - max. 14,5 Kw
Aria compressa	Compressed air	Druckluftanschluss	6 bar - 30 NI/c	6 bar - 30 NI/c.
Predisposizione circuito raffreddam.	Predisposition cooling system	Anschluss des Flüssigkeitskühlsystems	std	std
N.cicli macchina	Machine capacity	Maschinenleistung / Taktzahlen	6 - 10 cycles/min *	6 - 10 cycles/min *
Tipo di film	Film quality	Folienarten	flexible - semi rigid	flexible - semi rigid

\* I cicli macchina sono in funzione e dipendono dalla configurazione della macchina, dalla qualità dei materiali utilizzati e dal prodotto da confezionare. / Cycle speed depending on: material quality of tray and film web, tray size, product to pack and general machine configuration. / Die Leistung der Maschine hängt von der Folienart, ihrer Dicke und der geformten Ziehtiefe ab.

#### Optionals / Optionen :

- Fotocellula per film stampato  
Photocell centering printed film  
Druckmarkensteuerung der Oberfolie
- Circuito Vuoto & Gas  
Vacuum & Gas system  
MAP-Atmosphärenaustausch
- Pompa vuoto (100-200-300 m<sup>3</sup>/h)  
Vacuum pump (100-200-300 m<sup>3</sup>/h)  
Vakuumpumpen (100-200-300 m<sup>3</sup>/h)
- Unità di raffreddamento esterna  
External cooler unit  
Externes Kühlsystem

#### Lay-out ReeForm 350

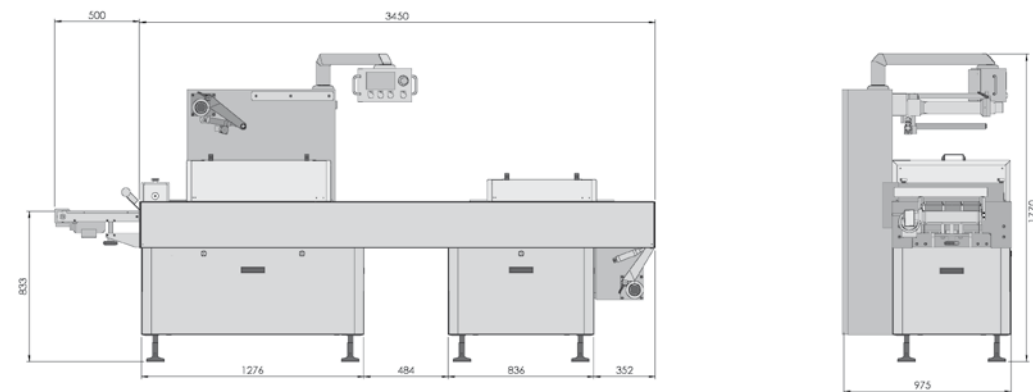

#### Lay-out ReeForm 420

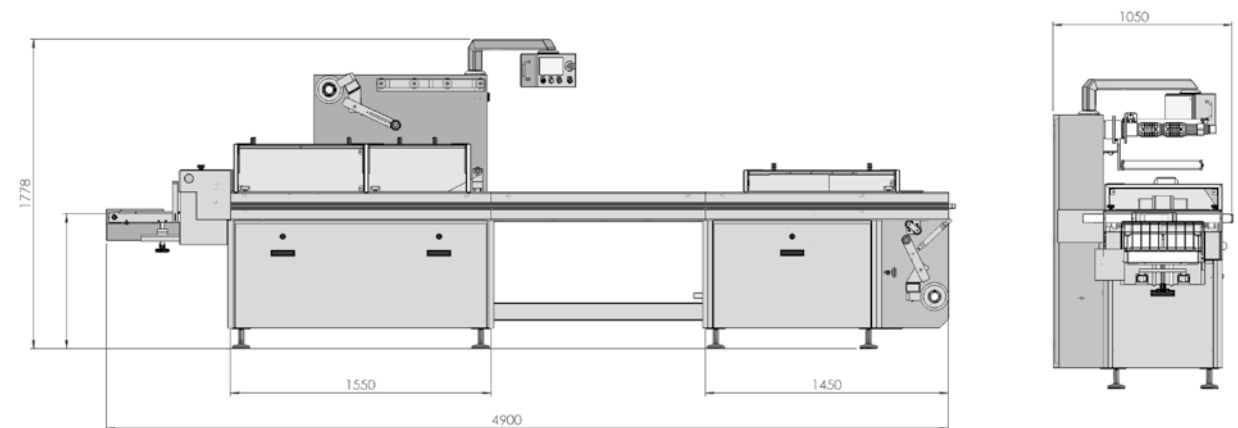

Copyright by Reepack srl - Rk001-0410

Si riserva la facoltà di apportare modifiche ai dati esposti senza alcun preavviso. / In keeping with improvements, designs and specification subject to change without notice. Die genannten technischen Angaben unterliegen laufender Verbesserungen. Daher sind diese unverbindlich und können ohne vorherige Ankündigung jederzeit geändert werden. / Modifications des dates techniques exposés à modifier sans préavis.



- Svolgitore bobina film superiore.
- Top film unwinder.
- Folienabwicklung Oberfolie.
- Récupération déchets.

- Aspiratore sfrido film.
- Aspirator film waste.
- Restfolien- Absaugung.
- Aspirateur déchets film.

- Taglio longitudinale.
- Longitudinal cutting.
- Laengsschnitt.
- Coupe longitudinale.

- Taglio laterale, max 2 tagli.
- Cross cutting, max 2 cross cutters.
- Querschneideeinrichtung (max. 2 Messer).
- Coupe latérale, max 2 coupes.

- Stazione di saldatura.
- Sealing station.
- Siegelstation.
- Station de soudure.

- Stazione di termoformatura.
- Forming station.
- Formstation.
- Station de thermoformage.

- Svolgitore bobina film inferiore.
- Bottom film unwinder.
- Folienabwicklung (Unterfolie).
- Dérouleuse bobine film inférieure.

- Area caricamento prodotto.
- Loading area.
- Produkteinfüllbereich • Zone de chargement du produit.

**Basic machine**

**Special machine**

- Display multifunzionale Touch Screen su braccio mobile.
- Multifunctional display with touch screen pad on movable arm.
- Multifunktionsdisplay mit Touchscreen.
- Display multifonctionnel Touch Screen sur un bras mobile.

Direzione film/ Film direction  
Laufrichtung der Folien / Directiones film



**ReeForm 350**

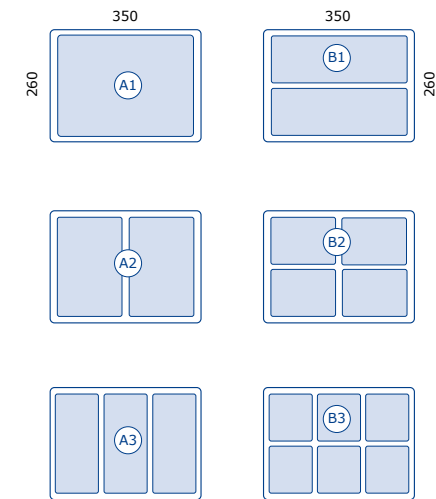

- A1= 297x239 mm
- A2= 139x239 mm
- A3= 85x239 mm

- B1= 297x109 mm
- B2= 139x109 mm
- B3= 85x109 mm

Numero cavità per ciclo. / Number cavity processed per cycle.  
Packungsformate. / Numéro de empreinte/cycle.



**ReeForm 420**

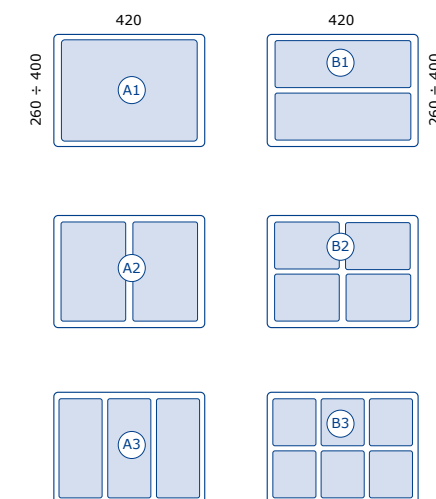

- A1= 369x239 ÷ 379 mm
- A2= 174x239 ÷ 379 mm
- A3= 109x239 ÷ 379 mm

- B1= 369x109 ÷ 179 mm
- B2= 174x109 ÷ 179 mm
- B3= 109x109 ÷ 179 mm

Direzione film/ Film direction  
Laufrichtung der Folien / Directiones film

